



# FICHA PRODUCTO/ PRODUCT DATA SHEET

DGI 02.06.02

REF. / SKU

DESCRIPCION / DESCRIPTION

REV

DATE

FIS400

FILTRO ARENA SIN BOMBA / INDEPENDENT TOP BLOW MOLDED FILTER

0

29/5/19

NEW COLLECTION 2020

## CARACTERÍSTICAS / CHARACTERISTICS

CODIGO / EAN13 CODE : 8412081304991

CAUDAL / FLOW RATE: 6 m<sup>3</sup>/h

MEDIDAS MONTADO / MEASURE: 40 x 40 x 70 cm CR: ? g

SAND CAPACITY: ± 35 kg NO INCLUIDA / NOT INCLUDED

PESO / WEIGHT: 5,340 Kg.

CONEXIONES/CONNECTIONS: Ø 32 / 38 mm - 1,5"- MANGUERA / HOSE: 54 cm

CUBA / BLOW MOLDED TANK: Ø 400 mm

VALVULA 6 VIAS / 6 WAYS VALVE

MANÓMETRO INCLUIDO / MANOMETER INCLUDED

BASE DE PLÁSTICO/PLASTIC BASE



## EMBALAJE / PACKAGING

UNIDADES ENVASE / UNITS: 1

MEDIDAS ENVASE / PACKAGE SIZE: 42 X 42 X 72 cm

VOLUMEN ENVASE / PACKAGE VOLUME: 0,127 m<sup>3</sup>

PESO UNITARIO / UNIT WEIGHT: 6,950 kg

PESO EMBALAJE / BOX PACKAGE WEIGHT: 1,600 kg

ETIQUETA / LABEL

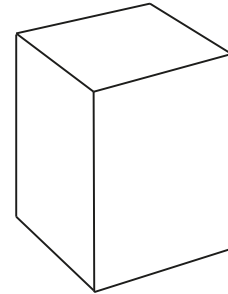

## PALETIZADO / PALETS

MEDIDAS PALET / PALET SIZE: 120 X 80 X 15 cm

MEDIDAS TOTAL PALET / TOTAL SIZE PALET: 126 x 84 x 159 cm

VOLUMEN TOTAL PALET / TOTAL VOLUME: 1,68 m<sup>3</sup>

6 CAJAS POR PLANTA / BOXES X 3 PLANTAS / LAYER

TOTAL EMBALAJES / PACKAGES PALET: 12

TOTAL DE UNIDADES PALET / UNITS PALET: 12

Peso total con palet / Total weight included palet: 103,4 kg

ETIQUETA IDENTIFICACION PALET / PALET LABEL

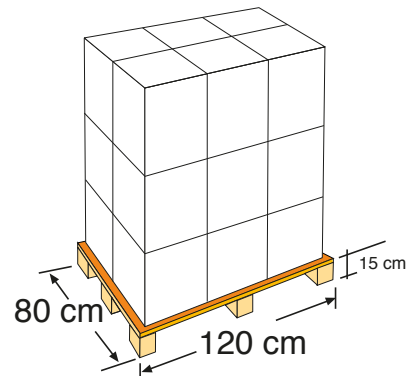

## OBSERVACIONES / OBSERVATIONS

FAMILIA: 160 - SUBFAMILIA: 000

UNIDAD ECOEMB: CARTON: 1.400 + 200 g - PLÁSTICO: ? g